

Master 50 Ford F250 - F350 2017 & + 8'

ARTICLE #	Qty	Description	Length
1	1	Plywood 5/8" cut at 3 1/2"	64 7/8"
2	1	Plywood 1/2" cut at 3 1/2"	65 5/8"
3	4	Plywood 5/8" cut at 3 1/2"	1 1/2"
4	12	Plywood 5/8" cut at 3 1/2"	1 5/8"
5	3	Plywood 5/8" cut at 3 1/2"	87"
6	1	Plywood 1/2" cut at 3 1/2"	66 1/2"
7	1	2 x 3	49"
8	6	Plywood 1/2" cut at 3 1/2"	87"
9	2	2 x 3	58 3/8"
10	4	Plywood 5/8" cut at 3 1/2"	7"
11	2	Plywood 1/2" cut at 3"	2 1/2"
12	3	Plywood 1/4" cut at 3 1/2"	6"
13	3	Plywood 1/8" cut at 3 1/2"	6"

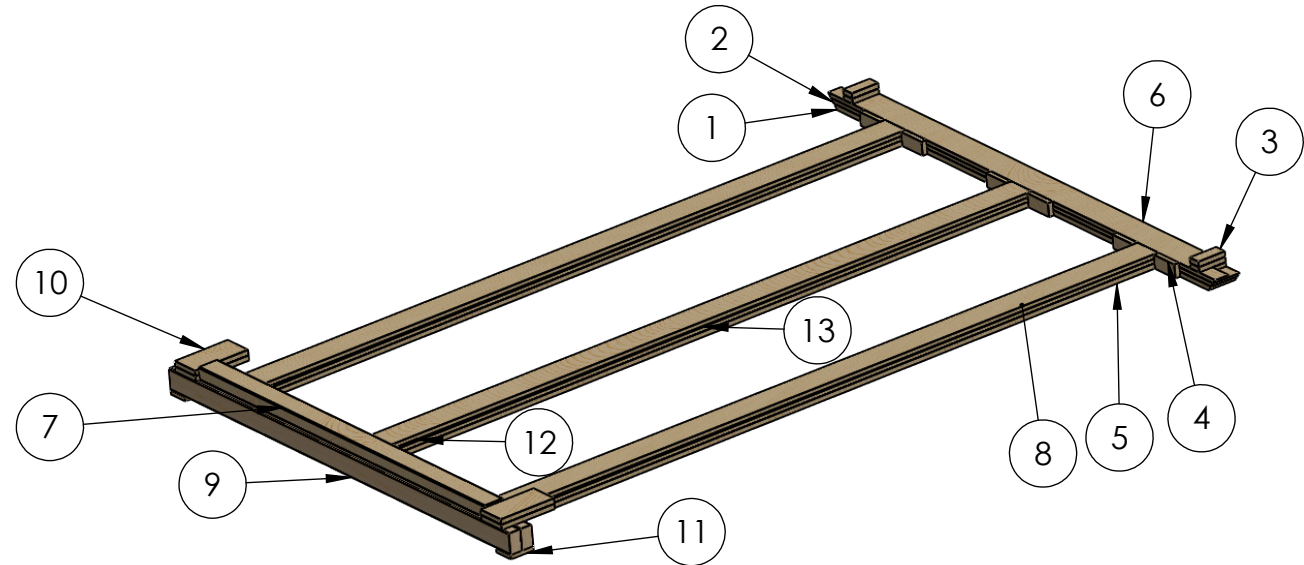

Description:

MORY inc.

701, rang St-Pierre - St-Anselme, QC - G0R 2N0
1-800-924-9804 - info@moryinc.com

Ownership and Confidentiality

The information contained in this drawing is the property of MORY inc.
All reproduction parts without written permission of MORY Inc. are
criminal offense.

Customer

KS-M50L-F250-2017+_eng

Drawn by: Stéphane Morin

Date: 2018-02-19

Scale: 1:20

SHEET 1 OF 2

Front

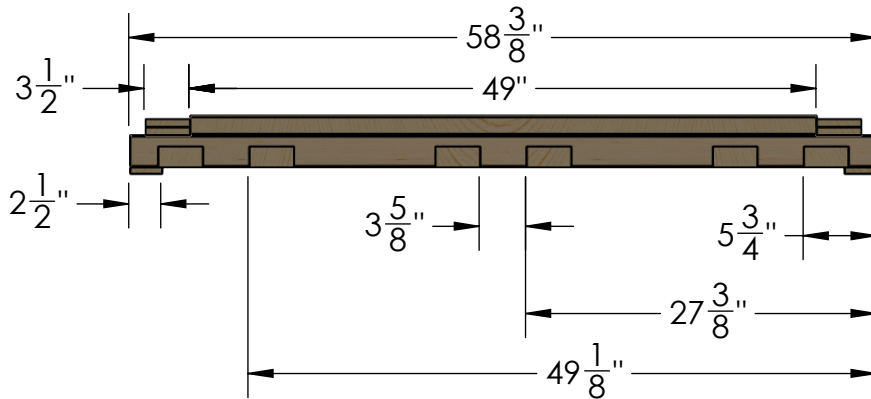
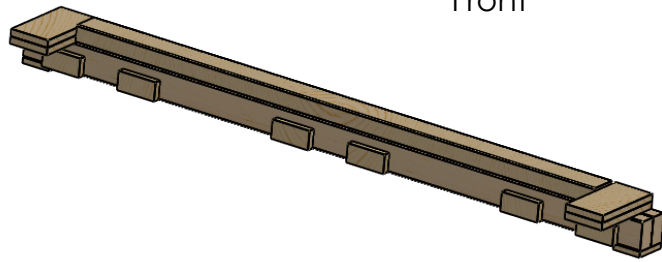

Rear

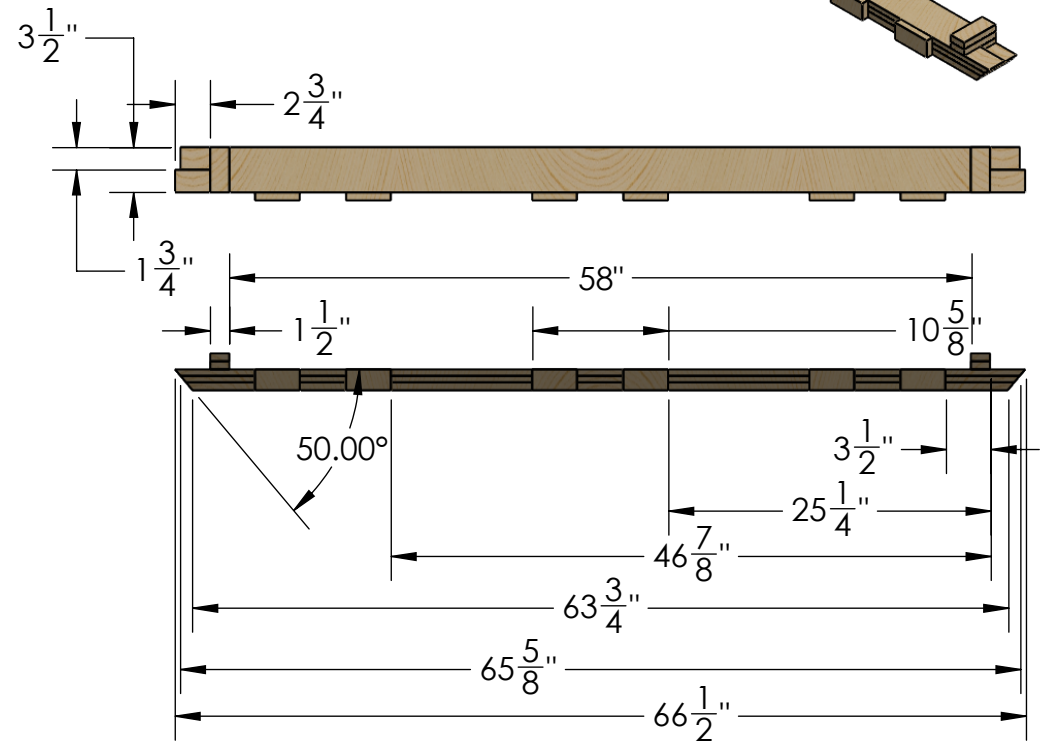
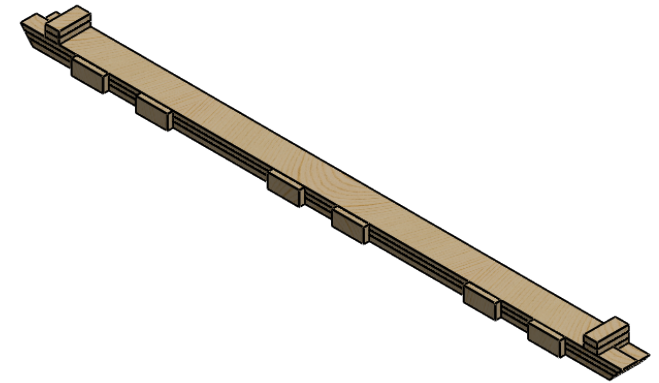

crossbar

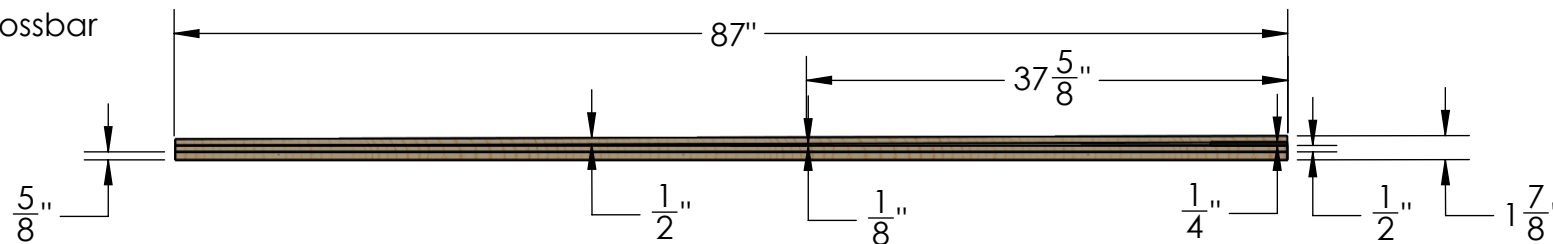

Description:

MORY inc.

701, rang St-Pierre - St-Anselme, QC - G0R 2N0
1-800-924-9804 - info@moryinc.com

Ownership and Confidentiality

The information contained in this drawing is the property of MORY inc.
All reproduction parts without written permission of MORY Inc. are
criminal offense.

Customer

KS-M50L-F250-2017+_eng

Drawn by: Stéphane Morin

Date: 2018-02-19

Scale: 1:15

SHEET 2 OF 2