

Master 75 new Ford F250 - F350 2017 & + 8'

ARTICLE #	Qty	Description	Length
1	1	Plywood 5/8" cut at 3½"	66 1/2"
2	1	Plywood 1/2" cut at 3½"	65 1/2"
3	2	Plywood 5/8" cut at 3½"	4 3/4"
4	1	Plywood 5/8" cut at 3½"	4 3/4"
5	1	Plywood 5/8" cut at 3½"	4 3/4"
6	12	Plywood 5/8" cut at 3½"	1 1/8"
7	3	Plywood 5/8" cut at 3½"	87"
8	3	Plywood 1/2" cut at 3½"	87"
9	2	2 x 3	58 3/8"
10	4	Plywood 5/8" cut at 3½"	7"
11	2	Plywood 1/2" cut at 3"	2 1/2"

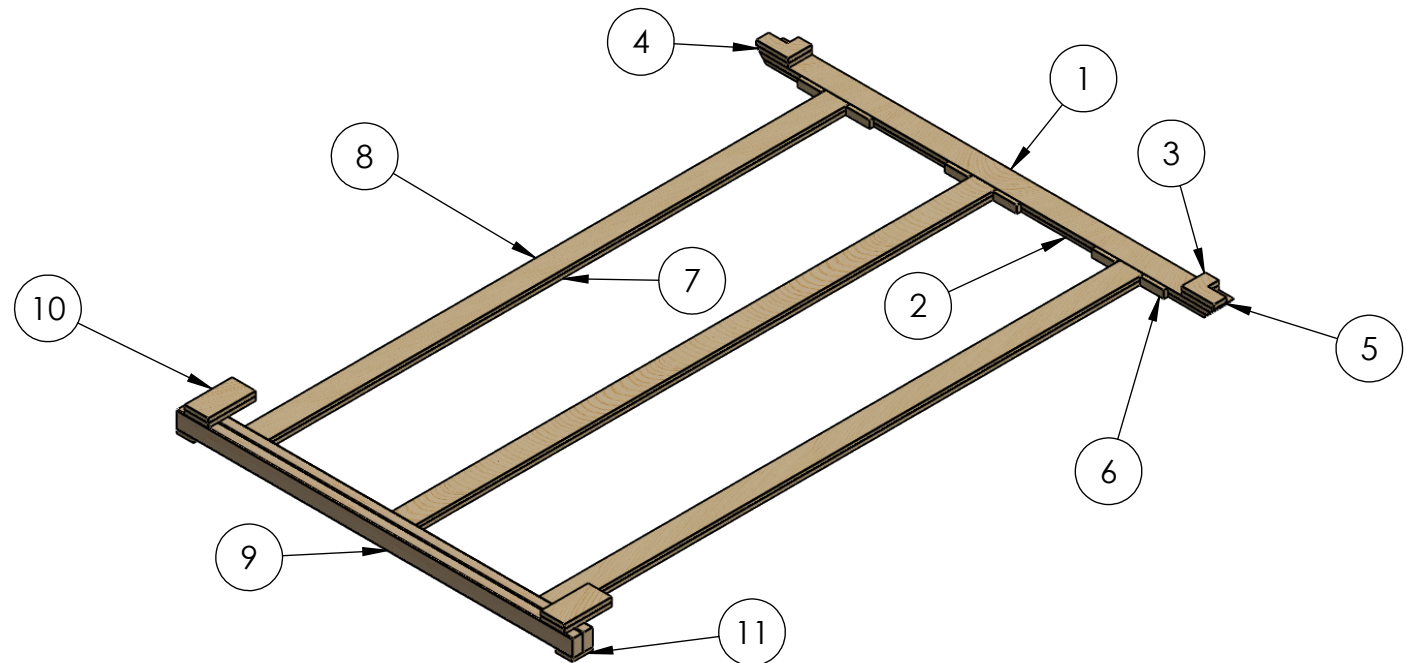

Description:

MORY inc.

701, rang St-Pierre - St-Anselme, QC - G0R 2N0
1-800-924-9804 - info@moryinc.com

Ownership and Confidentiality

The information contained in this drawing is the property of MORY inc.
All reproduction parts without written permission of MORY Inc. are
criminal offense.

Customer

KS-M75LN-F250-2017+_eng

Drawn by: Stéphane Morin

Date: 2018-02-19

Scale: 1:20

SHEET 1 OF 2

Front

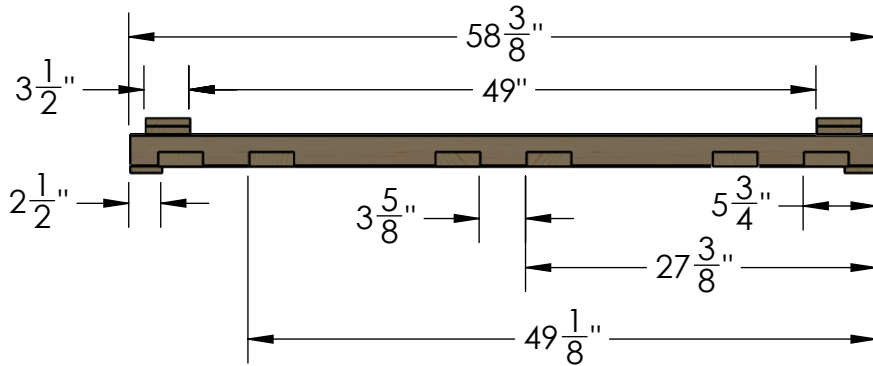
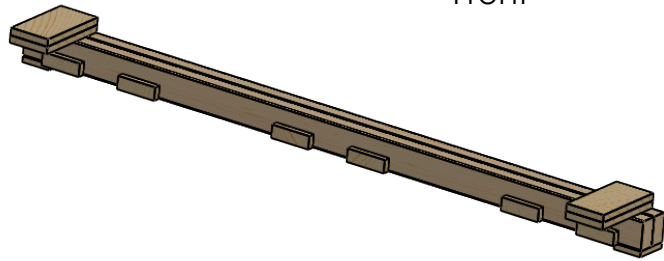

Rear

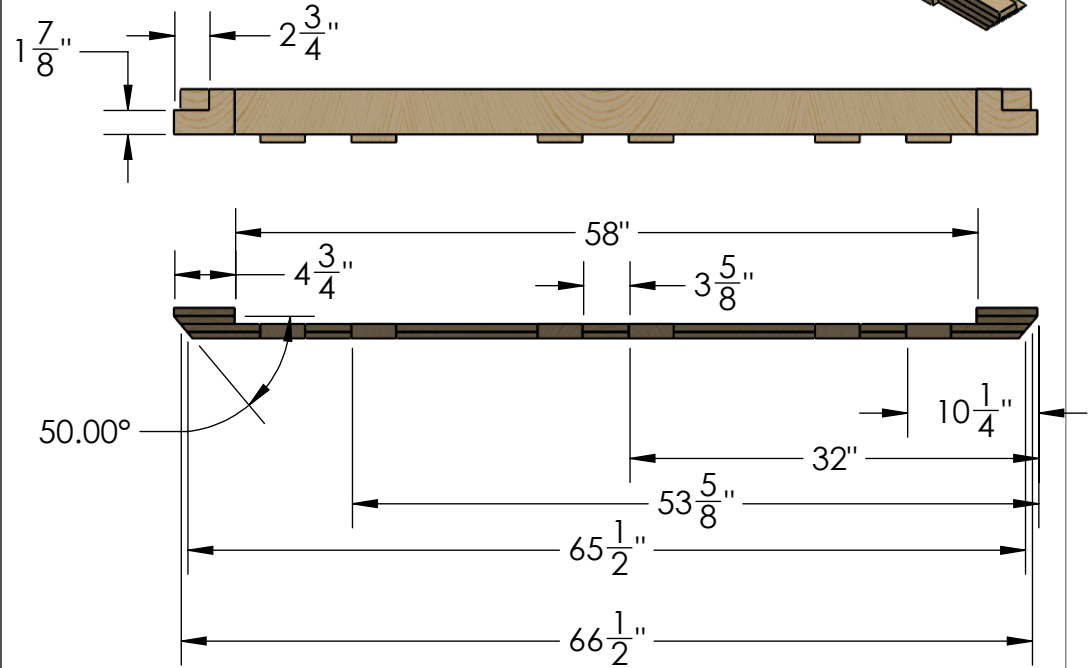
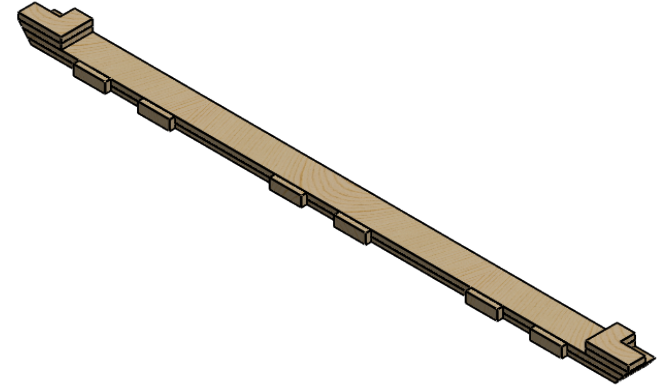

Crossbar

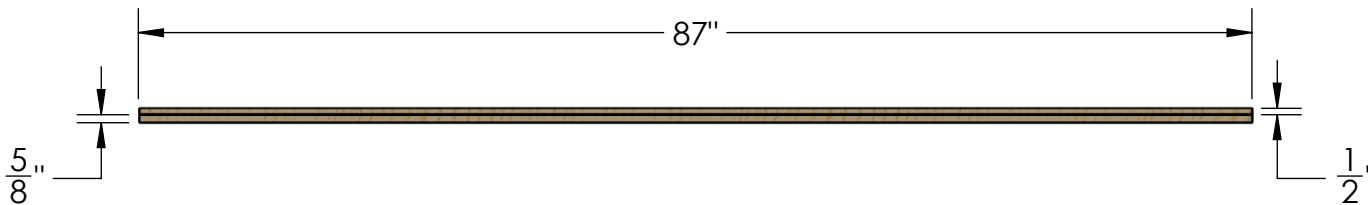

Description:

MORY inc.

701, rang St-Pierre - St-Anselme, QC - G0R 2N0
1-800-924-9804 - info@moryinc.com

Ownership and Confidentiality

The information contained in this drawing is the property of MORY inc.
All reproduction parts without written permission of MORY Inc. are
criminal offense.

Customer

KS-M75LN-F250-2017+_eng

Drawn by: Stéphane Morin

Date: 2018-02-19

Scale: 1:15

SHEET 2 OF 2