

Master 60 & 75 Ford F250 - F350 2017 & + 6 1/2'

ARTICLE #	Qty	Description	Length
1	1	2 x 4	66 1/2"
2	1	Plywood 5/8" cut at 3 1/2"	60 7/8"
3	16	Plywood 5/8" cut at 3 1/2"	1 1/2"
4	3	2 x 4	71"
5	1	Plywood 1/2" cut at 3 1/2"	60 7/8"
6	3	Plywood 5/8" cut at 3 1/2"	71"
7	2	2 x 3	58 3/8"
8	3	Plywood 1/2" cut at 3 1/2"	70 1/4"
9	4	Plywood 5/8" cut at 3 1/2"	7"
10	2	Plywood 1/2" cut at 3"	2 1/2"
11	2	Plywood 5/8" cut at 3 3/4"	49"

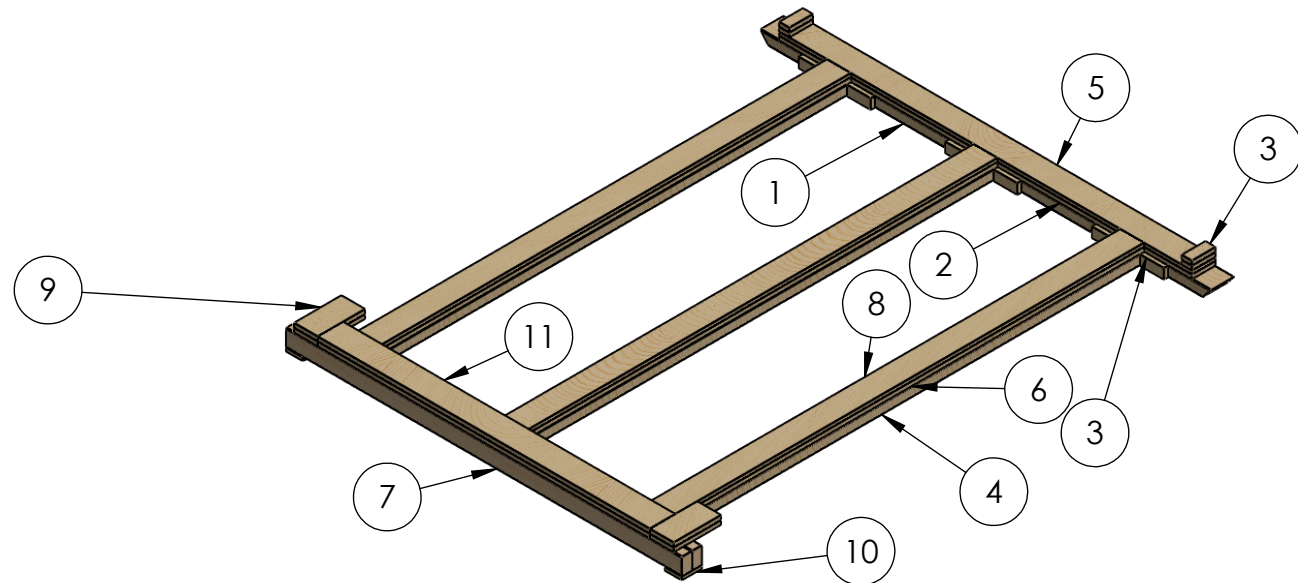

Description:

MORY inc.

701, rang St-Pierre - St-Anselme, QC - G0R 2N0
1-800-924-9804 - info@moryinc.com

Ownership and Confidentiality

The information contained in this drawing is the property of MORY inc.
All reproduction parts without written permission of MORY Inc. are
criminal offense.

Customer

KS-M60C-F250-2017+_eng

Drawn by: Stéphane Morin

Date: 2018-03-07

Scale: 1:20

SHEET 1 OF 2

