

Number	Description	Qty	LENGTH
1	2 X 4	1	62 7/8"
2	5/8" plywood cut to 3 1/2" width	2	2"
3	5/8" plywood cut to 3 1/2" width	2	2 1/2"
4	5/8" plywood cut to 3 1/2" width	12	1 1/2"
5	2 x 4	2	61"
6	2 x 4	1	49"
7	5/8" plywood cut to 6" width	1	5 5/8"
8	5/8" plywood cut to 6" width	2	7 1/2"
9	5/8" plywood cut to 6" width	1	6 1/4"
10	1/4" plywood cut to 3 1/2" width	3	6"
11	1/8" plywood cut to 3 1/2" width	3	6"
12	2 x 4	3	70"
13	1 x 3	1	49"
14	2 x 3	1	49"

# Master 50C GMC 2500 6 1/2' 2500 2020 & +

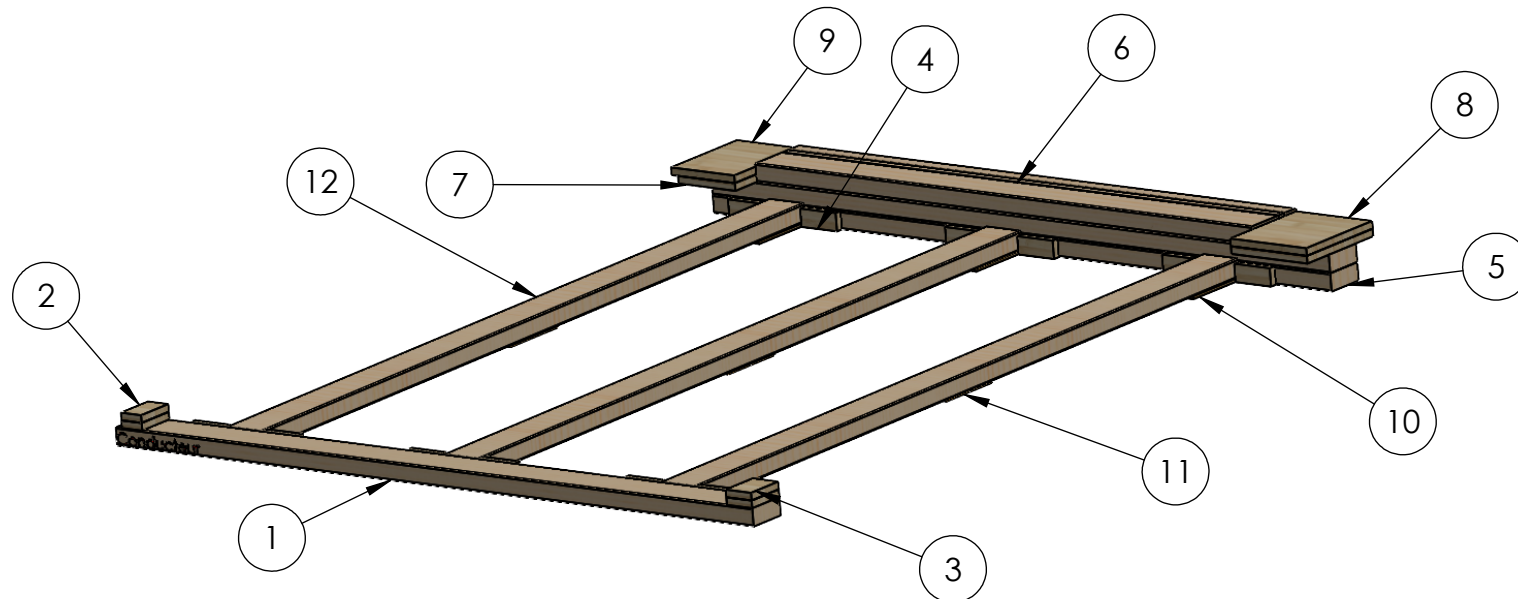

Description: Shim kit for Master 50 short GMC 2500 HD 2020 & +

**MORY inc.**

701, rang St-Pierre - St-Anselme, QC - G0R 2N0  
1-800-924-9804 - info@moryinc.com

**Ownership and Confidentiality**

The information contained in this drawing is the property of MORY inc.  
All reproduction parts without written permission of MORY Inc. are  
criminal offense.

Customer

M50C-SHGM-2500-20+\_eng

Drawn by: Stéphane Morin

Date: 2020-03-13

Scale: 1:15

SHEET 1 OF 2

# Front

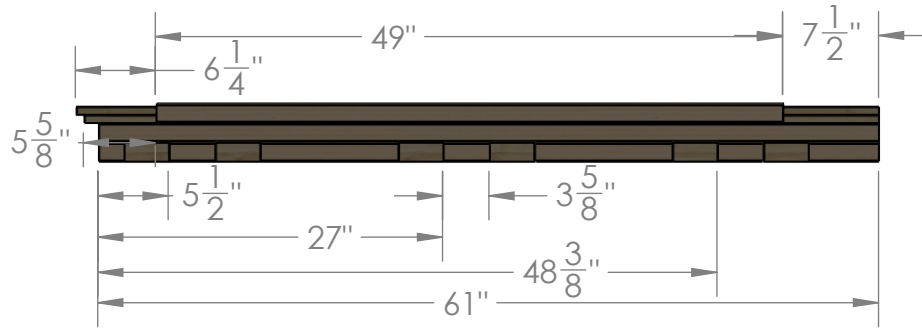
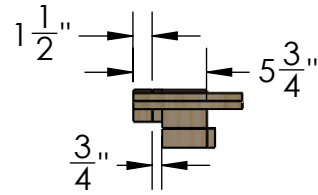
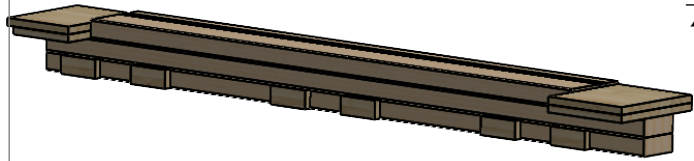

# Rear

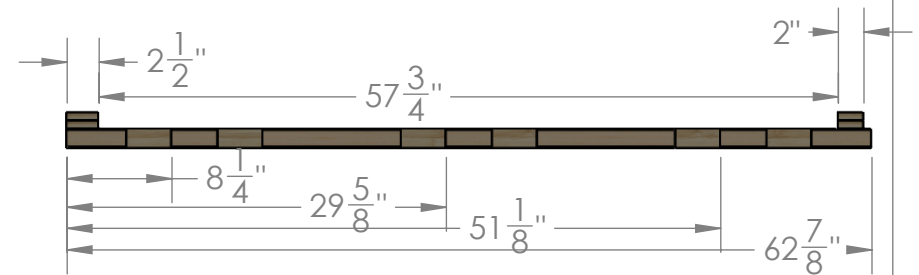
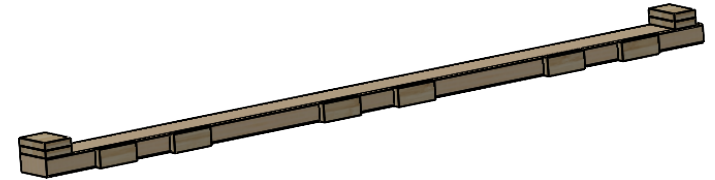

# Crossbar

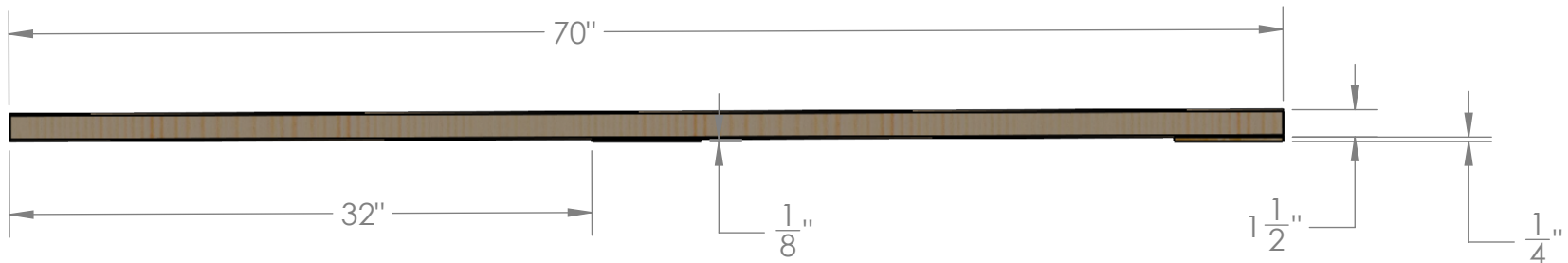

Description: Shim kit for Master 50 short GMC 2500 HD 2020 & +

**MORY inc.**

701, rang St-Pierre - St-Anselme, QC - G0R 2N0  
1-800-924-9804 - info@moryinc.com

**Ownership and Confidentiality**

The information contained in this drawing is the property of MORY inc.  
All reproduction parts without written permission of MORY Inc. are  
criminal offense.

**Customer**

M50C-SHGM-2500-20+\_eng

Drawn by: Stéphane Morin

Date: 2020-03-13

Scale: 1:15

SHEET 2 OF 2

# M50-M60-M75 Filler instalation for 2020 6.5' Chevy Trucks

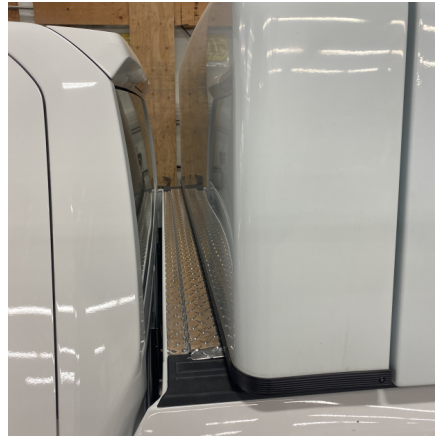

1 - Clean front of truck with  
99% Isopropyl Alcohol



2 - Remove red parts of 3M tape

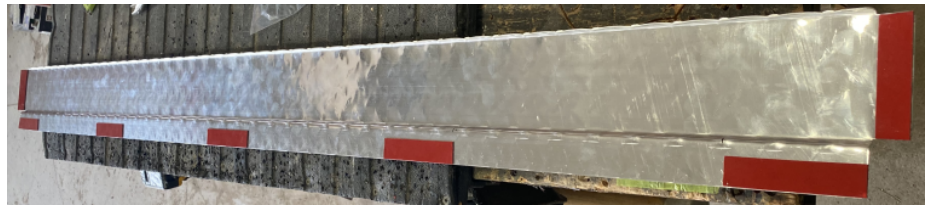

3 - Install filler on front of  
truck



4 - Press strongly where there is tape 3M

